

Final Drive Belt Tension Inspection

Drive belt tension must be measured using Triumph service tool T3880126, which is available from your Triumph dealer.

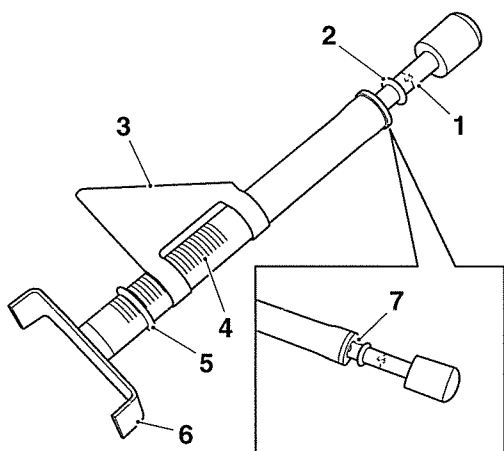

Service Tool T3880126

1. Load scale - 4.5 kgf (10 lbf) mark
2. O-ring
3. Deflection slider
4. Deflection scale (0.5 mm (0.020 in) increments)
5. O-ring
6. Belt cradle
7. Load scale (zero position)

Drive belt tension can be measured with the motorcycle on the side stand, or if available, on support stand T3880803 (available from your Triumph dealer). The method of measurement and adjustment is identical, but the belt tension specification for each method is different. Drive belt tension must be measured with the drive belt cold (at ambient temperature).

Position the motorcycle either on the sidestand or on the motorcycle support stand (service tool T3880803) as shown below.

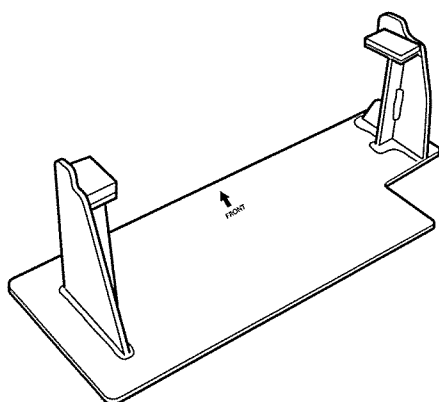

T3880803

Tool T3880803

The stand should be positioned with the arrow facing the front of the motorcycle, with the plastic pads located under each rear footrest bracket as shown below.

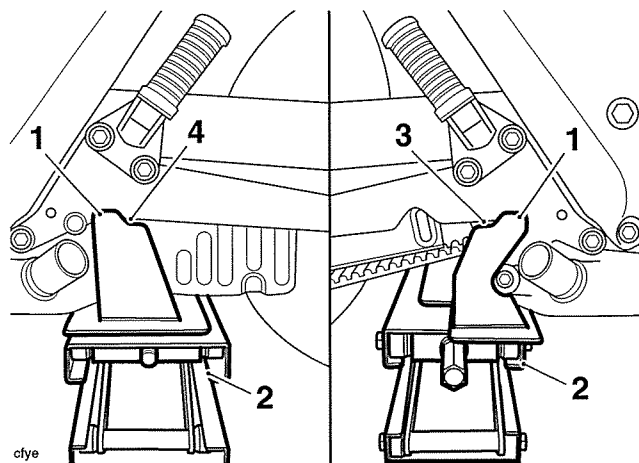

cfye

1. Tool T880803
2. Propriety motorcycle lifting jack
3. Plastic pad - right hand
4. Plastic pad - left hand

Raise the motorcycle so that the rear wheel is clear of the ground using a propriety motorcycle lifting jack.

Refer to the chart below for the correct drive belt tension specification for the method of motorcycle support you are using.

Drive Belt Tension Specification

Motorcycle on sidestand	5.5 to 7.0 mm (0.20 to 0.27 in)
Motorcycle on Support stand T3880803	7.5 to 9.0 mm (0.30 to 0.35 in)

Drive belt tension is measured by applying a 4.5 kilogram-force (kgf) (10 pound-force (lbf)) load to the plunger on service tool T3880126, once it has been positioned to the lower run of drive belt; this load then deflects the belt. The belt deflection can then be measured using a scale on the tool.

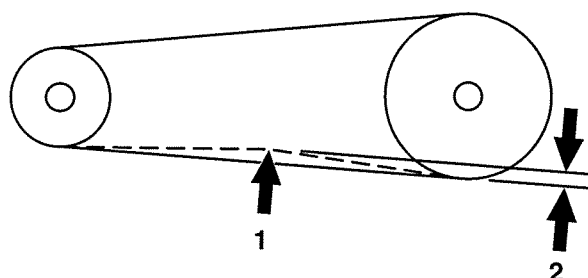

1. 4.5 kilogram-force (10 pound-force) applied to belt
2. Amount of deflection